

**HYDRAULIC ELECTRIC PUMPS (SOLENOID VALVE)**

- ✓ Remote pendant controlled solenoid valves with up, down and emergency stop button.
- ✓ Internal safety valve set at 700 bar to prevent overpressure.
- ✓ External adjustable pressure relief valve.
- ✓ For use with single acting or double acting cylinders for heavy lifting or production applications.
- ✓ HBE series are supplied with the a 3 metre remote pendant as standard, with up, down and emergency stop button.
- ✓ Options: roll bars and glycerine pressure gauge.

NOTE: Pressure gauge is not included.

**AZ89**  
Hydraulic Oil



P.85

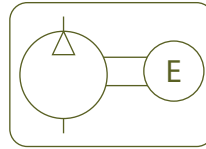

Type

**HBE**

Capacity

5 - 25 litres

Max. pressure

700 bar

Capacity	A	B	C
l	mm	mm	mm
5	370	230	500
8,5	390	310	525
12,5	410	390	550
25	470	360	670

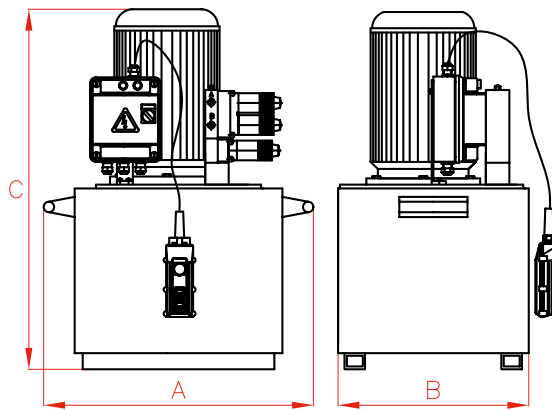

**ELECTRIC PUMPS (SOLENOID VALVE)**

Tank Size	Flow 700 bar	Flow 50 bar	230V-1ph-50Hz	400V-3ph-50/60Hz	Motor Power	Pump Weight
			litres	l/min		
5	0,36	4,00	HBE7271	HBE7274	0,75	27
8,5	0,54	5,90	HB33371	HB33374	1,10	35
12,5	0,54	5,90	HB33471	HB33474	1,10	43
12,5	0,82	8,64	HBE4471	HBE4474	1,10	45
25	1,64	14,00	HBE5571	HBE5574	2,20	83

**PUMP OPTIONS**

add letter behind pump model number



**C Roll Bar**

- ✓ Protects pump and components: motor, valves, etc
- ✓ For easy portability.
- ✓ Different sizes available.



**G Glycerine Pressure Gauge**

- ✓ ± 1,6 % full scale
- ✓ Reliable pressure measurement.
- ✓ Pressure range: 0-1000 bar.